

7-0 INCH COMMERCIAL GRADE WOOD CHIPPER

YARDBEAST[®]



7027



CHIPPING POWER THAT IS SIMPLY UNMATCHED

Let the Yardbeast do
the work.
You earn the money.

27 HP!
KOHLER

POWER
Unleashed!

The Yardbeast 7027 is more than just a wood chipper; it's a statement. It's a declaration of your intent to conquer even the most daunting brush and branches.

With its 7-inch chipping capacity and monstrous appetite for woody debris, the 7027 is the ultimate tool for professional landscapers, arborists, and anyone who means business when it comes to yard cleanup.

For more details, visit our website at www.yardbeast.com
For inquiries, contact us at (305) 396-3396 or at sales@yardbeast.com



Crafted with meticulous attention to detail, the Yardbeast 7027 isn't just another wood chipper – it's an investment in uncompromising quality and performance.

We get it. You want to conquer your jobsite, not wrestle with complicated controls. That's why the Yardbeast 7027 is designed for intuitive operation and minimal setup. Fire it up, feed in the branches, and watch as mountains of woody debris transform into manageable piles of chips – all with little effort on your part.

SIMPLICITY OF DESIGN PUT TO HARD WORK

The Yardbeast is fueled by a dual-reversible blade, 180-degree cutting fury. Picture two razor-sharp blades (like hungry sharks!) mounted on a massive 1" x 25" steel disc, spinning with unstoppable momentum. This beast generates enough inertia to pulverize even the thickest limbs and logs, spitting out a satisfying rain of woodchips.

4,200
cuts/min

For more details, visit our website at www.yardbeast.com
For inquiries, contact us at (305) 396-3396 or at sales@yardbeast.com

FEATURES



All-around hydraulic feeding control bar fabricated of high gauge tubing. Flat profile when chipper tray is closed optimizing the chipper footprint.



Electronic programmable hydraulic feed controller allows the chipper to maintain optimal blade RPM when chipping. Reverse and delay programmable.



Forget fickle shaft alignment! SKF®'s self-aligning bearings delivers smoother performance, extended life, and reduced maintenance.



Cast-iron heavy duty Hydraulic fluid regulator controls the feeding speed of the feed roller. A 1,500 psi preset safety valve ensures system safety at maximum loads.

FEATURES



The Beast comes with super sharp blades made of A8 steel, providing flexibility yet a tough edge with exceptional abrasion resistance. These blades are reversible.



DOT compliant enclosed lightning on the trailer with standard 4-prong connector terminal and 2-inch side turn signals.

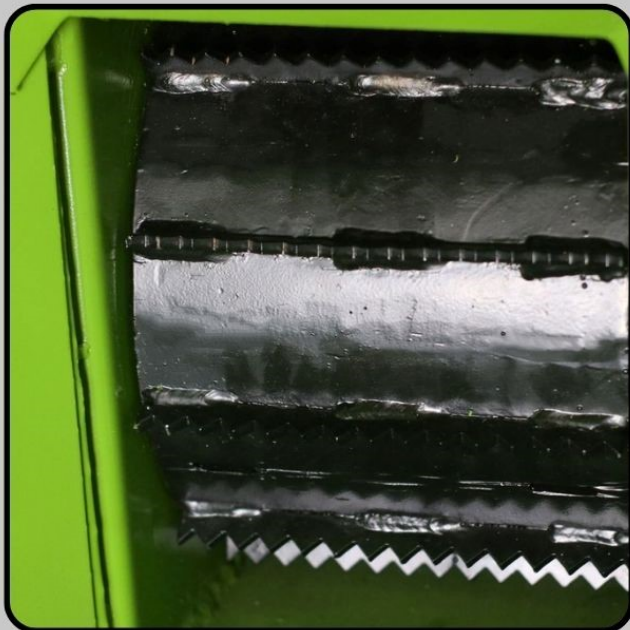

10-inch feed roller with 12 rows of razor teeth delivering up to 550 lb of crushing power that will suck branches with small twigs attached reducing pruning times.



ST235/85-15 high speed tires coupled to a torsion axle-less suspension for a smooth highway and offroad ride and superior overcome of obstacles.

FEATURES

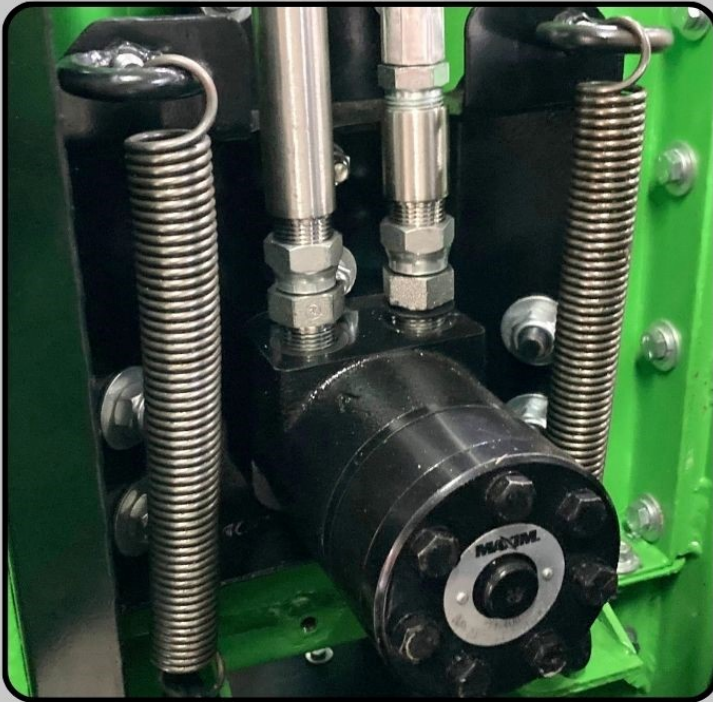

Feeding assembly comprises of a single 10-inch feed roller controlled by four tension springs. Carriage is mounted on 8-angular sealed bearings for superior responsive feeding. Hydraulic motor delivers up to 2,150 lb-in torque at slow speeds. Feeding speed up to 200 ft/min. Feeding system is completely enclosed to increase operator safety.



Auto warning light that turns on automatically when the engine is started alerting operators and bystanders that the chipper is currently under power.



Blade change port allows quick inspection or change of the edge of the blade, or perform a blade replacement. Safety is improved with rotor locking mechanism.

MORE FEATURES..

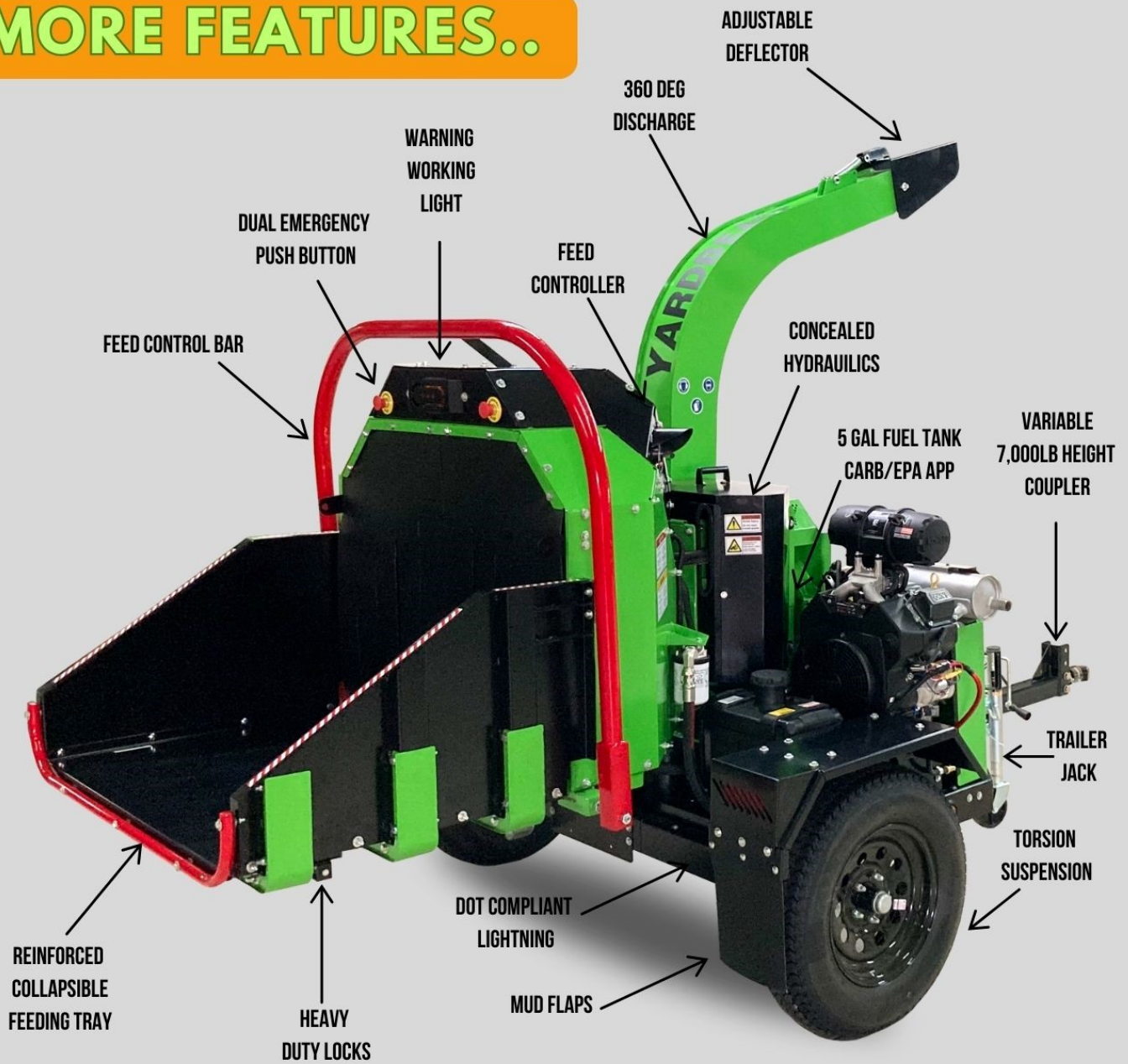

DIMENSIONS

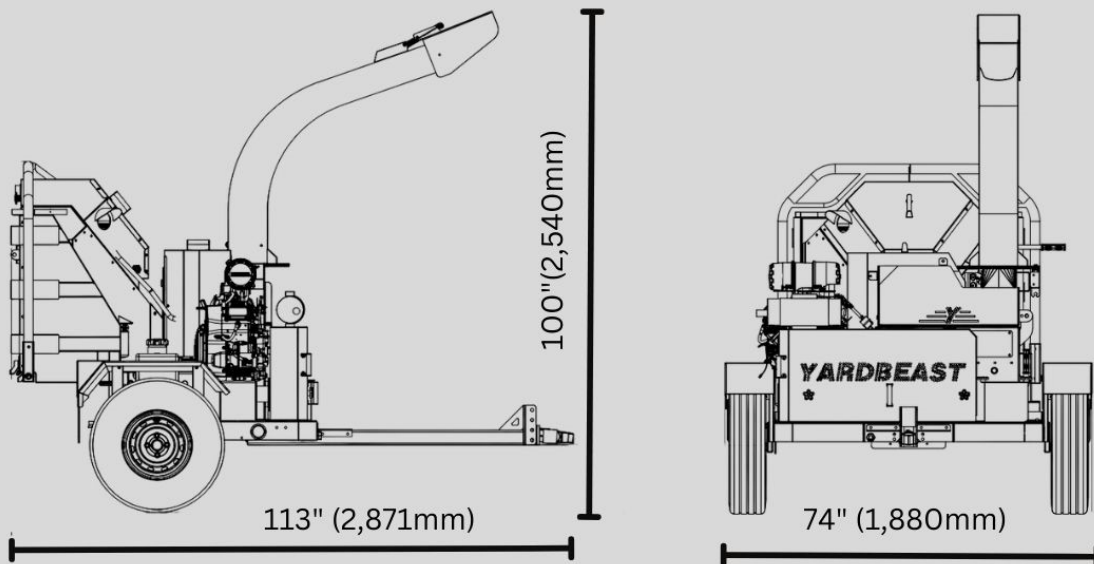

SPECIFICATIONS



CHIPPER

- Chipping capacity: 7.0" (178mm)
- Rotor Weight: 150-lb, Rotor RPM: 2,300 approx.
- Blade: 2 - A8 Tool Steel Reversible Blade. Dual blade configuration across 180-deg.
- Blade dimensions: 8.4" x 4" x 1/2" with single bottom Anvil knife bed.
- Flywheel Construction 25" x 3/4" thick steel with 3/8" rotor vanes
- Feed Hopper: 31" x 41" wide collapsible chute pan for transport and Automatic Operating Warning Light
- Frame construction: High gauge thick steel. Weld seams all around
- Bearing units: SKF® or NTN® premium roller sealed bearings /custom forged housing
- Discharge height: 360-degree x 85" height with 12-in discharge deflector controlled by chain link
- Radial 10-inch Feed Drum with Dual Suspension mounted on precision bearing carriage
- Chipper Weight (w/engine): 1,650 lbs.

HYDRAULICS

- 5-gal heavy duty oil tank with magnetic debris trap and oil sight level
- Maxim® Gear Pump: 0.48CID, 3.9 GPM @ 2000 RPM, 3650 PSI
- Maxim® Hyd. Motor: 14.9 CID, 1625 PSI @240 RPM, 3,185 ft-lb Max Torque
- Maxim® Flow Regulator , 3000 PSI. Adjustable Speed.
- Auto-Feed Plus® Electronic Feed Control with Work Hours logger and Programmable Features.

ENGINE

- Make: Kohler® CH752-3100 Command Pro 27HP V-twin with Heavy Duty Air Filtration System
- RPM: 3,300
- Peak Torque: 42.2 ft-lb (57.2-Nm) @ 3,000RPM
- Dry Weight: 105 lbs.
- Displacement: 747cc

TANK SYSTEM

- Fuel Tank Capacity 5.0 Gal EPA/CARB Fluorinated Gas Tank with Vapor Canister Vapor Suppression system .

TRANSMISSION

- Drive: NorAM® Centrifugal Automatic PTO engagement Clutch
- Belts: Banded Heavy Duty 3-rib belt
- Rotor Pulley: 9-inch Cast Iron pulley with 3-groove. mounted on industrial sized tapered hub

TRAILER

- Wheels: ST235/85R16 (Highway/Offroad)
- Frame construction: Sectional Mono-chassis with structural linkage for improved rigidity
- Total Frame width: 68"
- Suspension: 2,000-lb Torsion stub suspension
- Guards: Belt Guard with 3-point support
- Rear Axle: Fixed, 1/8" Steel thick 21-1/4" wide
- Hitch: 2-inch Class-II Ball hitch with Variable height and chain hooks
- Trailer: DOT Compliant Trailer with suspension and lightning kit

For more details, visit our website at www.yardbeast.com

For inquiries, contact us at (305) 396-3396 or at sales@yardbeast.com

Our goal is to make the best chippers.

We take pride in being a customer-oriented organization. We design, fabricate, test, and ship our units directly to our dealers and customers like you.

Since our origins, it has been our mission to provide second to none quality wood chippers that will stand the test of hard work in time. We achieve that by combining a variety of factors such as simplicity of use, heavy-gauge materials, top-quality third-party components, and a one-user operating and maintenance design mindset.



Owners of our chippers will confirm that they have a sturdy, powerful, top quality product that delivers. We're proud not only of our chipper's efficient abilities but also for its sleek design. In fact, we love every part of it! We think you will too.

At Yardbeast, we stand behind our products and fully support our commercial customers by offering a limited 1 year or 1,000-hr US commercial warranty that includes consistent and reliable technical advice, spare parts, and a network of US-domestic servicing dealers to provide a fast turnaround from downtime to operation.

Once you get to know your Yardbeast, you will find yourself with an easy to use, dependable piece of equipment that will be there to help you through your yard clearing jobs for many seasons to come.

**Have Questions?
Get in touch!**

☎ (305) 396-3396

✉ sales@yardbeast.com